

# Automatic Door Systems



**SW-2**

Swing Door

**使用説明**

**OPERATION INSTRUCTION**

<http://www.kthtw.com>  
e-mail: [kth@kthtw.com](mailto:kth@kthtw.com)



本公司另有以下各類自動門配備,請洽本公司各經銷商  
Our company has the following series of automatic door, please contact with our distributors/representations.

### 圓型門 Round type door

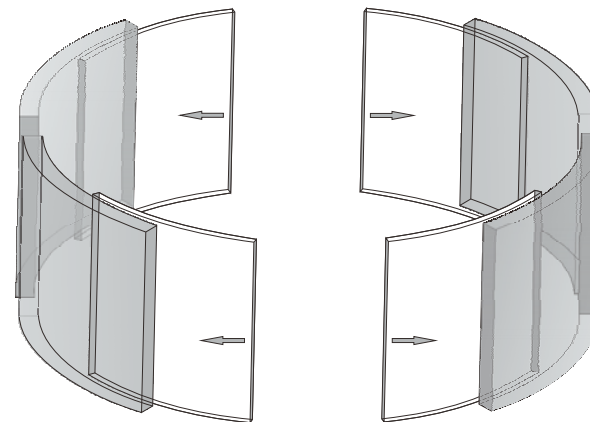

按裝方式請參考圓型門按裝說明

Installation: Please in accordance with the instruction of Round Type Door.

### 弧型門 Curved Type Door

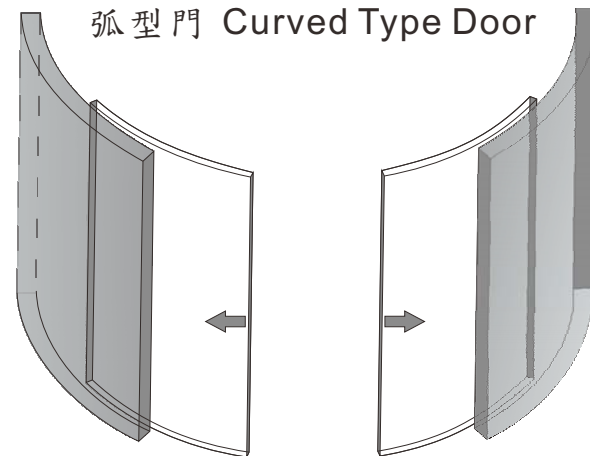

按裝方式請參考弧型門按裝說明

Installation: Please in accordance with the instruction of Curved Type Door.

供給電源輸入端  
AC100V~240V皆可

Power Supply (input)  
Either AC100V~240V

連接至控制器

To join the CONTROLLER

電源開關

POWER SWITCH



警告

請確認感應器所標示之電壓是否與供給電源相同,若與供給電源電壓不同時,則感應器需另行加裝變壓裝置否則感應器極易燒毀,連接完畢後,請再確認一次。



Warning

Please confirm WHETHER the SENSOR VOLTAGE is the same as the power supply. If different between them, need to add the TRANSFORMER, otherwise the SENSOR would be burned.

四扇走雙向門  
Telescopic 4-winged Sliding Doors.

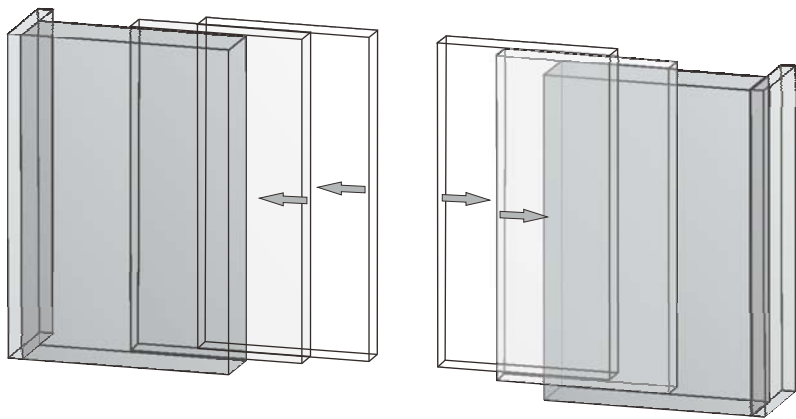

按裝方式請參考四扇走雙向門按裝說明

Installation: Please in accordance with the instruction of Telescopic 4-winged Sliding Doors.

雙扇走單向門  
Telescopic 2-winged Sliding Doors.

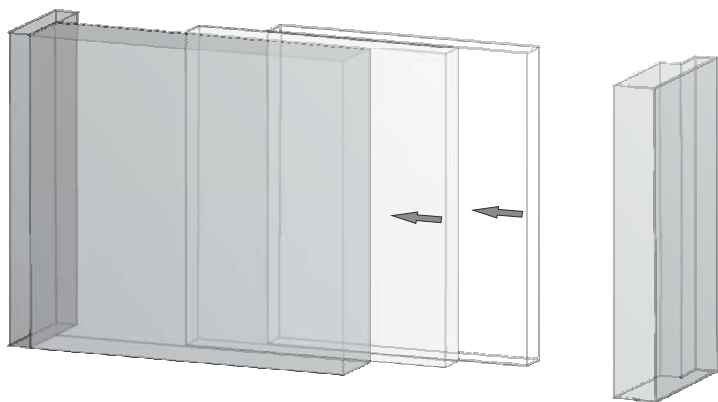

按裝方式請參考雙扇走單向門按裝說明

Installation: Please in accordance with the instruction of Telescopic 2-winged Sliding Doors.

多門互控主從有電鎖

Double Doors with Interlock, Electronic lock, Master/Slave Function

第一組門 1st of Double Door

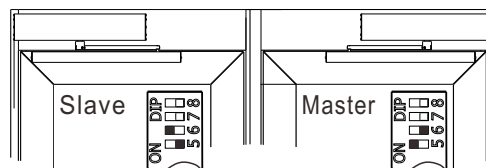

請設定先關門的為主機(5 On、6 Off)，  
後關門的為副機(5 Off、6 On)。

Please set the door which closes first  
to master(5 on, 6 off) then set the  
second to close to slave(5 off, 6 on).

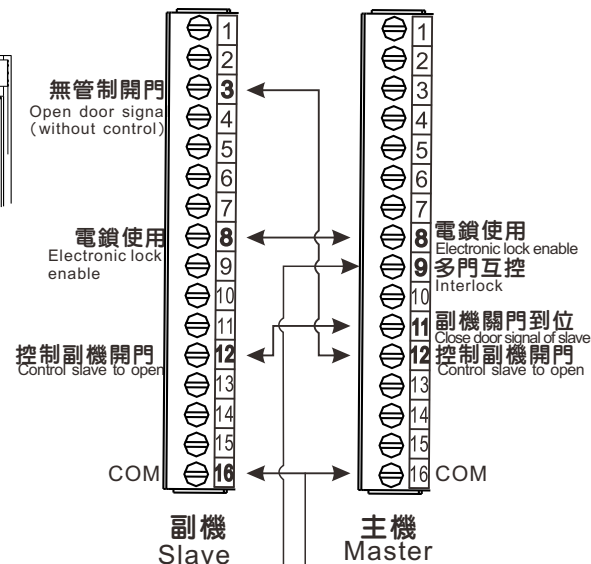

第二組門 2nd of Double Door

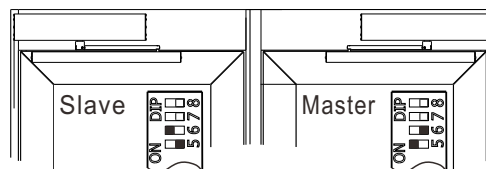

請設定先關門的為主機(5 On、6 Off)，  
後關門的為副機(5 Off、6 On)。

Please set the door which closes first  
to master(5 on, 6 off) then set the  
second to close to slave(5 off, 6 on).

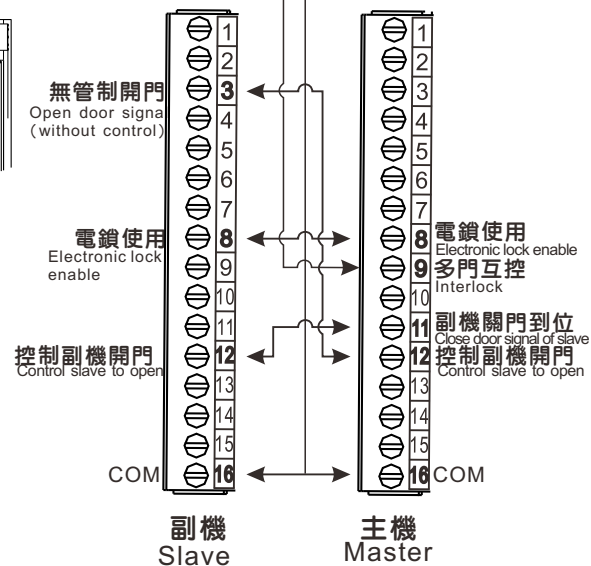

雙門示意圖 Double Door (I)

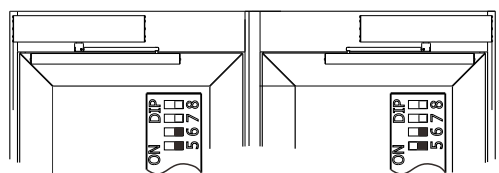

無管制開門  
Open door signal  
(without control)

請設定二台主機指撥開關的5、6狀態皆為Off。

Please set all door (5 Off, 6 Off).

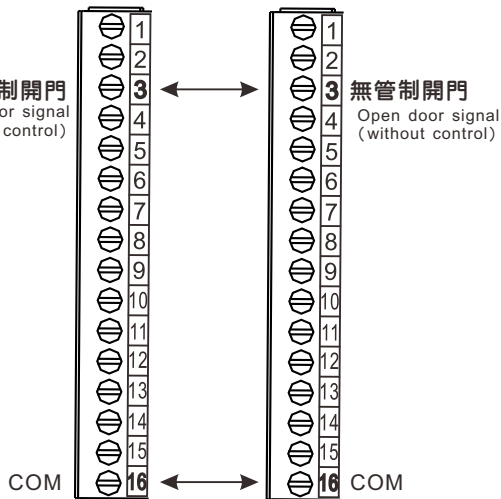
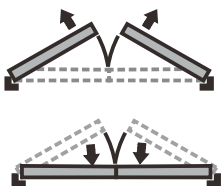

主從有電鎖雙門示意圖 Double Door (II) With Electronic Lock and Master/Slave Function

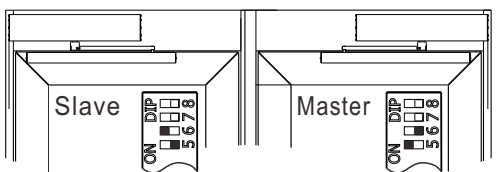

無管制開門  
Open door signal  
(without control)

請設定先關門的為主機(5 On、6 Off)，  
後關門的為副機(5 Off、6 On)

Please set the door which closes first  
to master(5 on, 6 off) then set the  
second to close to slave(5 off, 6 on).

電鎖使用  
Electronic lock  
enable

控制副機開門  
Control slave to open

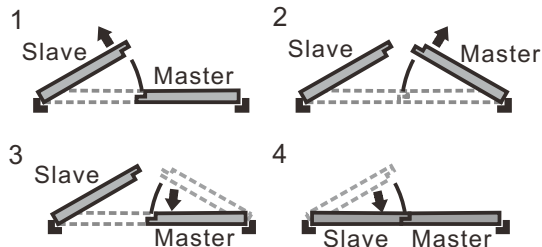
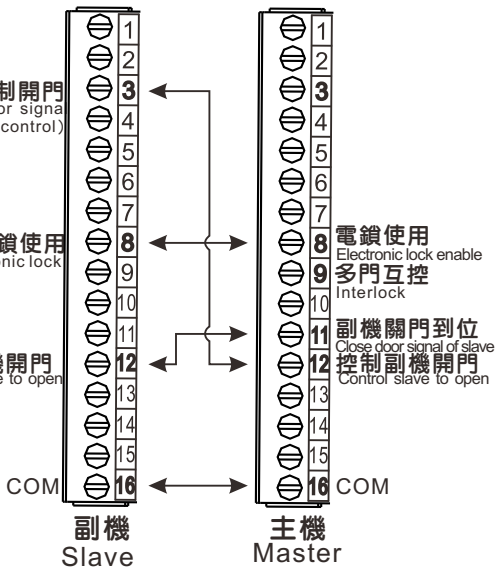

1. 產品規格 TECHNICAL SPECIFICATION..... P1
2. 門機組各部件說 DESCRIPTION OF OPERATOR..... P2
3. 門機組尺寸圖 OPERATOR (SECTION)..... P3
4. 開門幅度設定說 DISTANCE SETTING..... P4
5. 外推式按裝示意圖 (OUTWARD OPENING) PUSH ARM ASSEMBLY MOUNTING. P5
6. 外推式部件說 (OUTWARD OPENING) PUSH ARM ASSEMBLY ILLUSTRATION. P6
7. 內拉式按裝示意圖 (INWARD OPENING) PULL ARM ASSEMBLY MOUNTING. P7
8. 內拉式部件說 (INWARD OPENING) PULL ARM ASSEMBLY ILLUSTRATION..... P8
9. 各旋鈕功能說 ADJUST BOARD INSTRUCTION..... P9
10. 信號連接說 CONNECTION TO TERMINAL BLOCK..... P10
11. 雙門/主從關係 DOUBLE DOOR AND MASTER/SLAVE FUNCTION. P11
12. 多門互控(兩道雙門) INTERLOCK, ELECTRONIC LOCK, MASTER/SLAVE FUNCTION..... P12
13. 電器連接 CONNECTION..... P13

型號 MODEL	SW-2	
種類 TYPE	外推式 (Outward)	內拉式 (Inward)
門扇重量/寬度 DOOR WEIGHT & WIDTH	<p>最大值: ● Max.</p> <p>最小值: ● Min.</p>	
馬達 MOTOR	DC24V 120W 直流無刷馬達 DC24V 120W BRUSHLESS DC MOTOR	
控制器 CONTROL	微電腦化處理機控制器 USER-FRIENDLY MICRO-CONTROLLER	
消耗電量 POWER CONSUMPTION	120W	
電源電壓 VOLTAGE	AC100V~240V	
環境溫度 ENVIRONMENTAL TEMPERATURE	-20°C~+50°C	
噪音量 VOLUME	最大 55 分貝 55 decibel(max.)	
開啟速度 SPEED of OPENING 90 DEGREE	最大值: 0.2秒~0.5秒/90° 0.2~0.5 sec. (Max)	
開啟時間 STARTING TIME	可調 0 秒至 20 秒 0~20 sec. (Regulable)	
傳動要件 TRANSMISSION IMPORTANT CONDITION	外推式連桿組 Outward Arm assembly	內拉式滑動槽 Inward Arm assembly
開門幅度 OPENING DOOR RANGE	自行設定/90°(出廠值) 120°Max./90 (default)	
PFC 功率因素 POWER EFFICIENCY	0.95(AC100V全載時) 0.95 (In full load)	
手推開啟力量 TRACTION FORCE	2.5 kg	

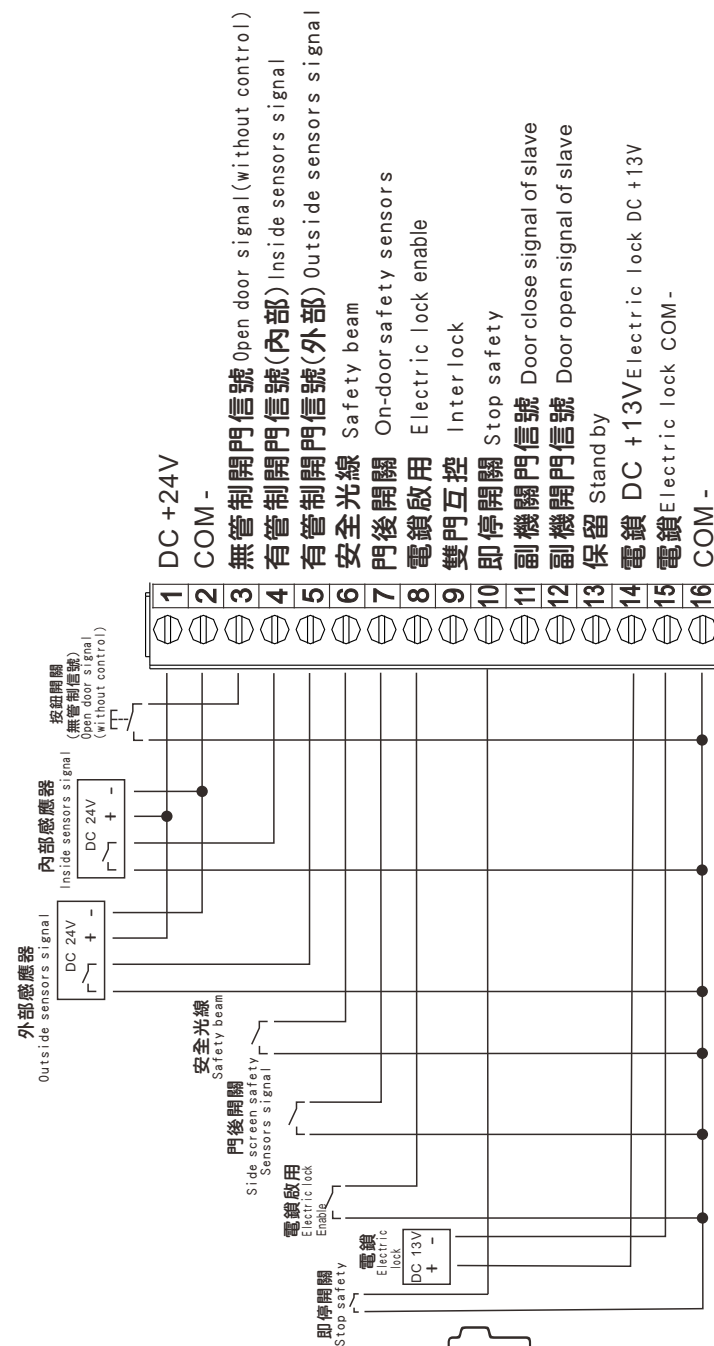

下電鎖時保全系統功能自行啟動:停電後再復電後, 門扇先執行關門動作

When connect to electronic lock, the reverse switch will be connected too: after power resumes, the Door-leaf closes the door first.



- 黃 Yellow** ● 設定開門幅度：  
燈亮表示設定行程中  
Setting door opening range:  
When light on you can set the door range.
- 綠 Green** ● 燈亮表示信號已輸入  
Signal input
- 紅 Red** ● 電源指示：  
燈亮表示電源已接通  
Power on

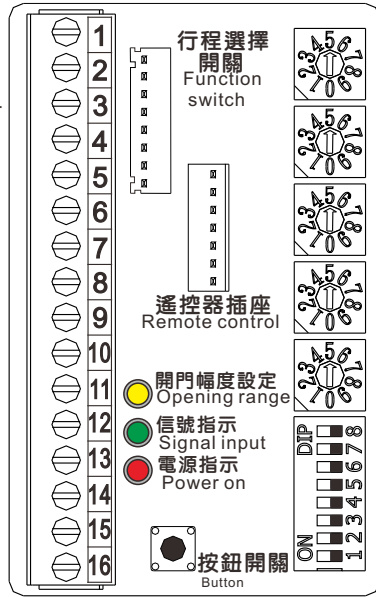

指撥開關功能敘述 (Fingered switch functions)		
8	OFF	開門幅度設定(最大120度) Opening range (Max. 120)
	ON	開門幅度設定90度(出廠值) Opening range
7	OFF	關門電鎖接點NC Fail-safe (lock, NC.)
	ON	關門電鎖接點NO Fail-secure (lock, NO.)①
6	OFF	不設定為副機 Set to slave-OFF
	ON	設定為副機 Set to slave-ON
5	OFF	不設定為主機 Set to Master- OFF
	ON	設定為主機 Set to Master- ON
4	OFF	無定向功能 Directional Function- OFF
	ON	有定向功能 Directional Function- ON
3	OFF	煞車力量-大 Brake power-Large
	ON	煞車力量-小 Brake power-Little
2	OFF	煞車功能-有(門扇50kg以上) Brake power-ON (over 50 KG.)
	ON	煞車功能-無(門扇50kg以下) Brake power-OFF (under 50 KG.)
1	OFF	開門方向-左開 Opening direction-Left
	ON	開門方向-右開 Opening direction-Right

Note: ① Power to unlock (only continue 5 seconds)

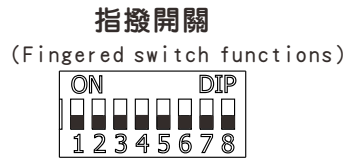

**\* 注意：**  
若為單一門扇時，指撥開關5與6必須設定為 Off 狀態。

**\* ATTENTION:**  
When only use 1unit operator,  
the pin 5 and pin 6 must set to off state.

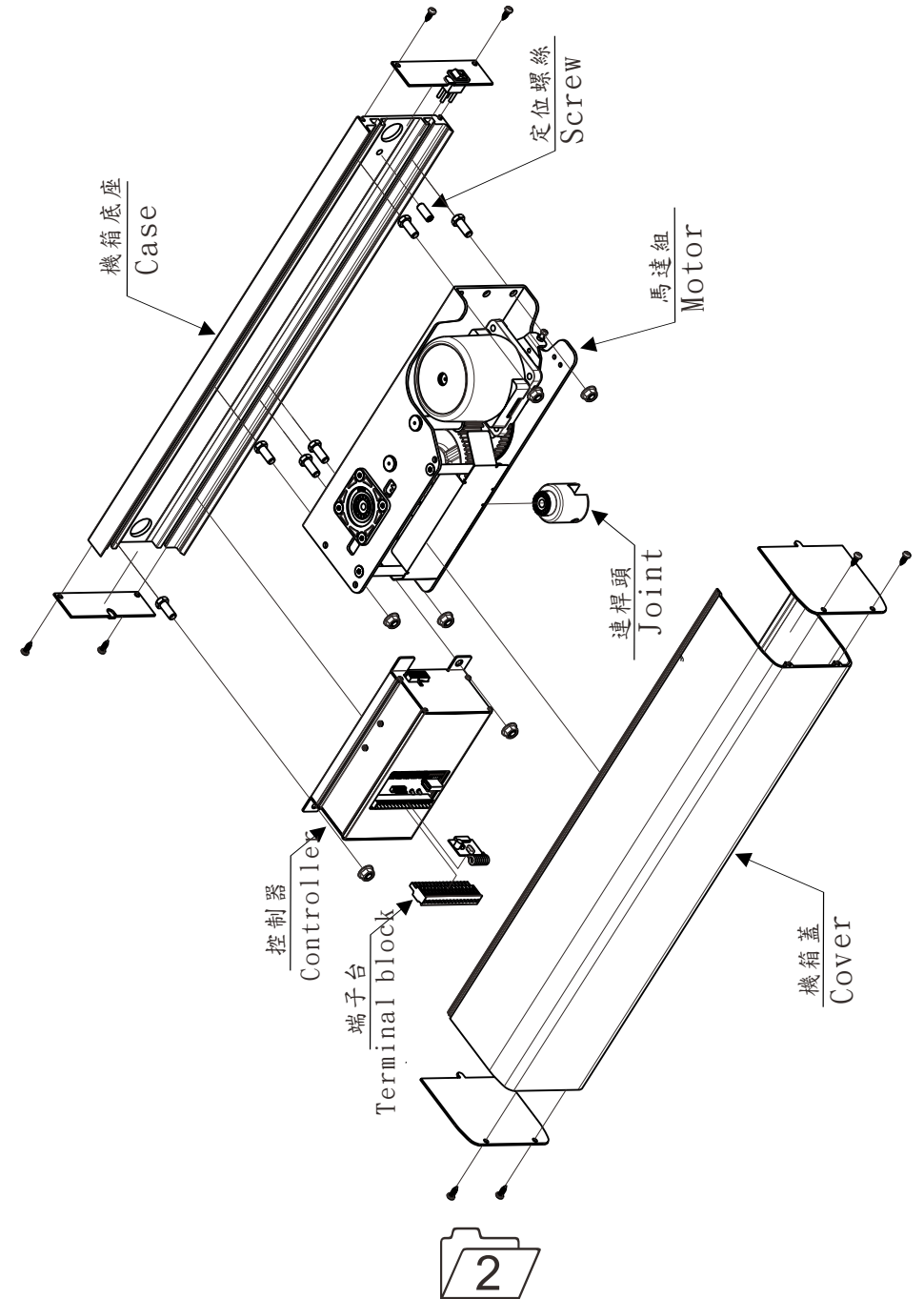

正視圖  
Front View

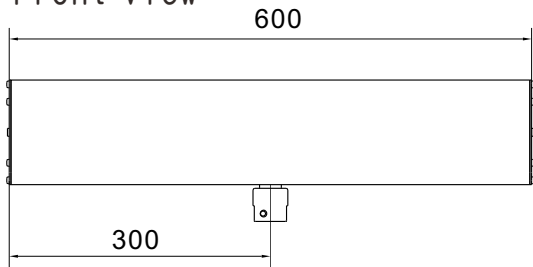

側視圖  
Side View

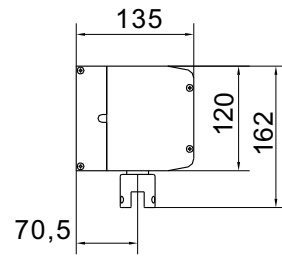

底座尺寸圖  
Base Size

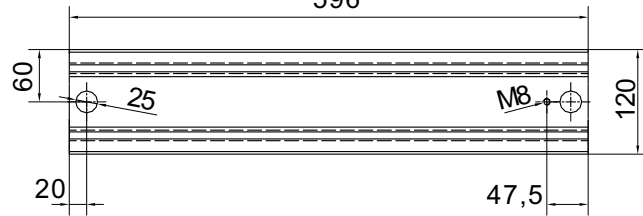

每組門機皆可搭配內拉或外推式配件

Every set of operator can use the Inward / Outward Arm assembly.

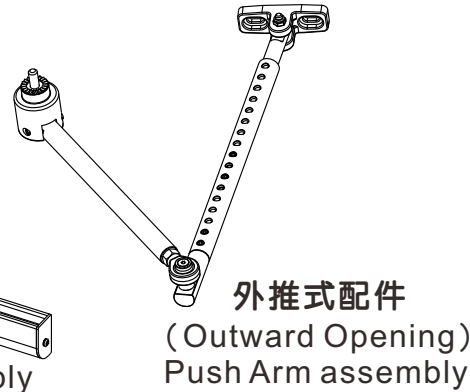
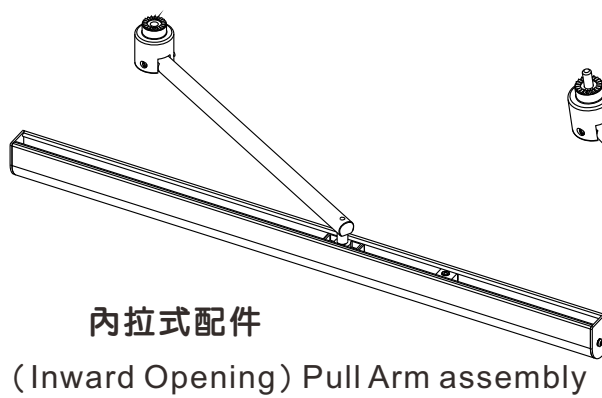

內拉式  
按裝示意圖  
Operator

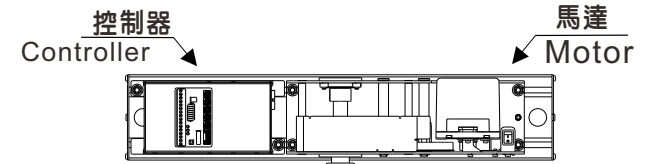

連桿頭  
Joint

註：無論是外推式和內拉式，左側門或右側門  
馬達永遠是按裝在右側。  
Motor has to be mounted the right side  
of the controller, no matter it's  
Outward/Inward/ Left Open/Right Open.

內拉式滑槽  
示意圖  
Inward Opening Pull Arm assembly

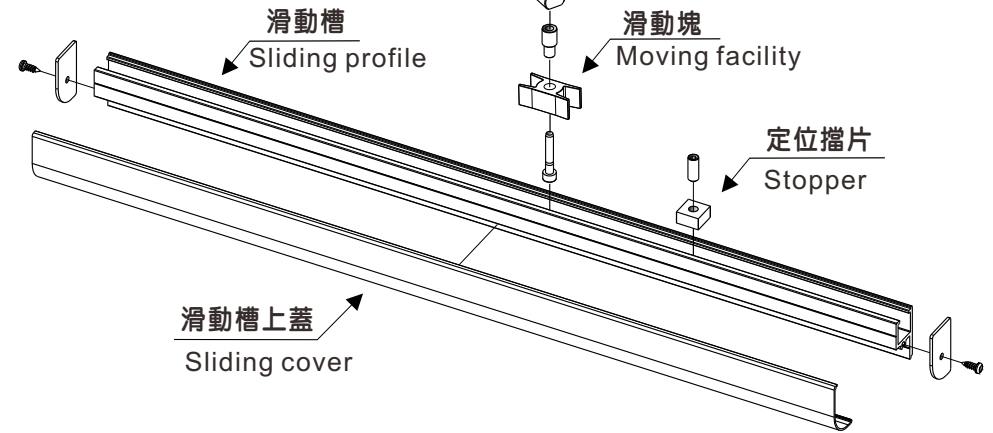



內拉式(左側)  
Left Open

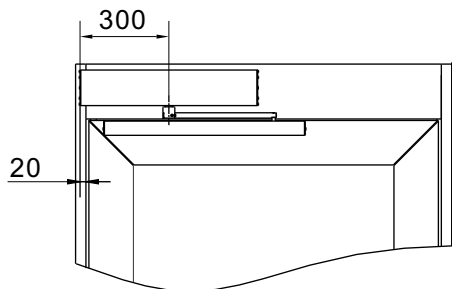

內拉式(右側)  
Right Open

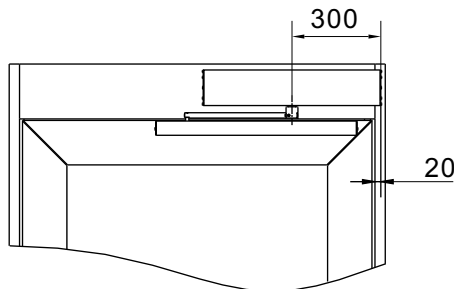

內拉式滑動槽按裝尺寸圖  
The position of mounting

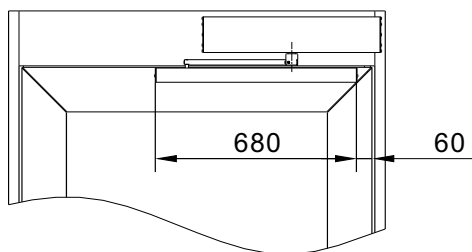

內拉式門機按裝尺寸圖  
Mounting (Side View)

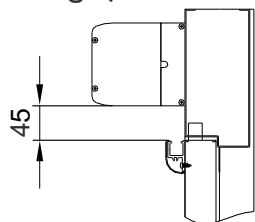

內拉式左側開門方向

Mounting (eg. for Left Open, Top View)

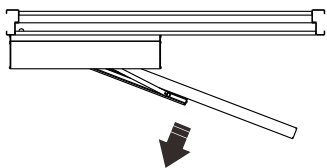

內拉式右側開門方向

Mounting (eg. for Right Open, Top View)

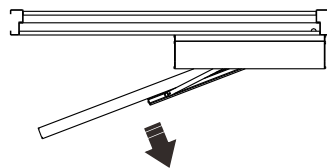

行程設定區  
(可自由設定)  
Set freely

行程最大值  
Max. 120

行程最小值  
Min. 35

可利用手、腳或門擋器  
來設定開門行程  
(行程設定後即可移除)

When the yellow light on,  
please set the distance of  
opening range.  
(By hands, feet or stoppers  
when door opening.)

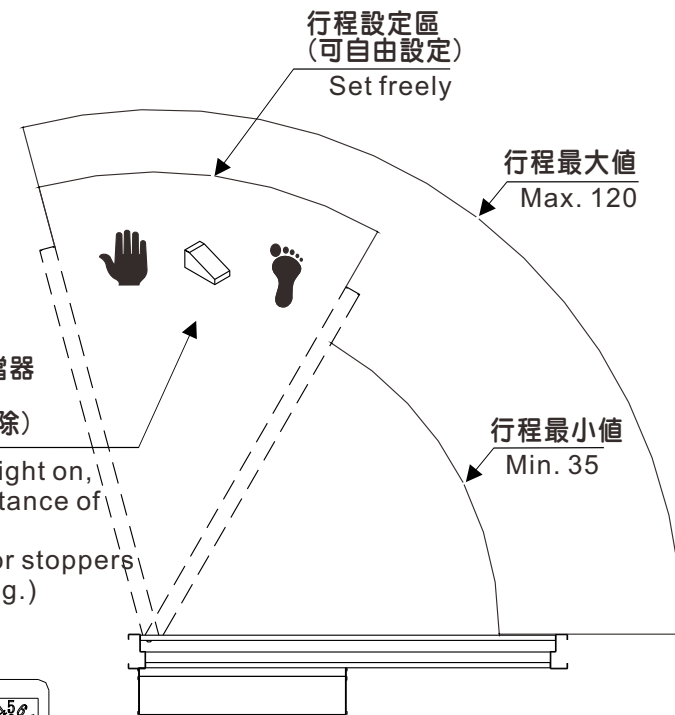

黃 ● 開門幅度設定：

當電源開啟後，15秒內按下按鈕開關，  
黃燈亮時表示目前正在設定行程中。  
註：開門行程最大值為120度，最小值  
則根據使用情況自行調整。

Yellow ● Opening Distance Setting:

When power on, press the button  
in 15 sec. And make sure the yellow  
light on then can set door opening range.  
P.S. The max. Of the opening range is 120

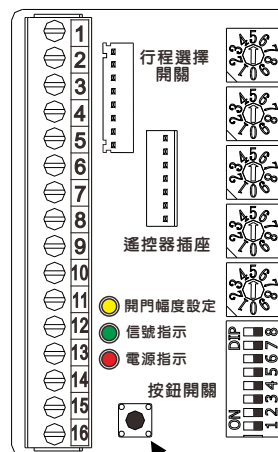

電源開啟後，15秒內按下按鈕開關後，  
即進入設定行程模式。

When power on, press the button  
in 15 sec. To enter the setting mode.

外推式(左側)  
Left Open

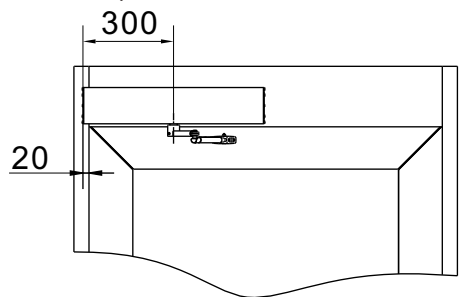

外推式(右側)  
Right Open

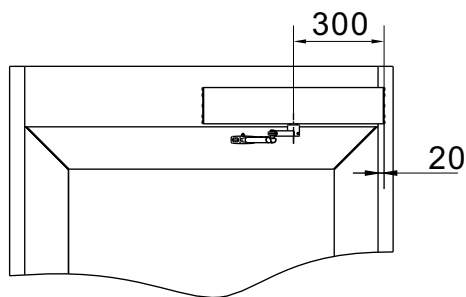

外推式推桿按裝尺寸圖

The position of mounting

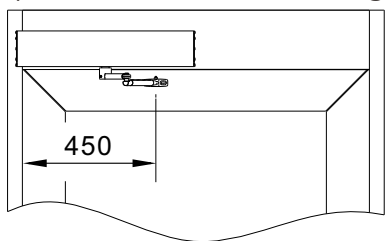

外推式門機按裝尺寸圖

Mounting (Side View)

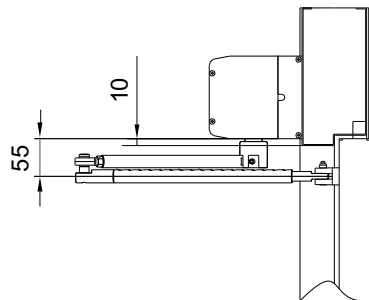

外推式開門方向(左側開門)  
Mounting (eg. for left Open, Top View)

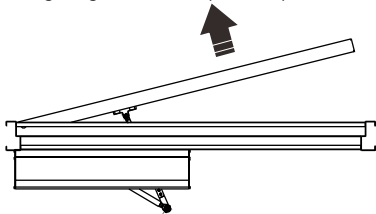

外推式開門方向(右側開門)  
Mounting (eg. for Right Open, Top View)

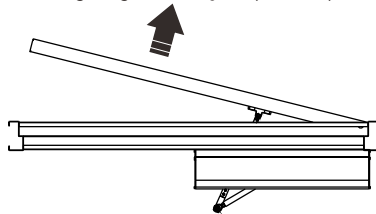

外推式  
按裝示意圖  
Operator

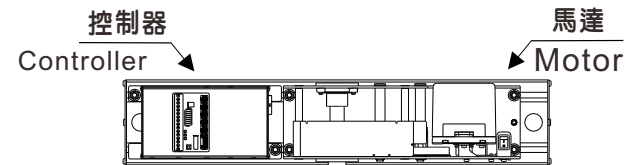

註：無論是外推式和內拉式，左側門或右側門  
馬達永遠是按裝在右側。

Motor has to be mounted the right side  
of the controller, no matter it's  
Outward/Inward/ Left Open/Right Open.

外推式連桿  
示意圖  
Inward Opening  
Push Arm assembly

