

Automatic Door Systems



SW-5E

Swing Door

(EN16005)

使用説明

OPERATION INSTRUCTION

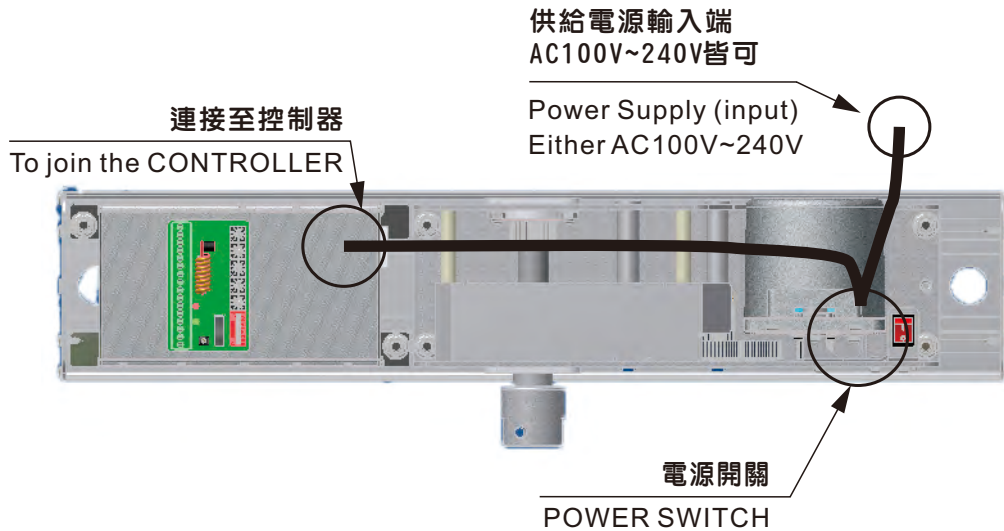

警告

請確認感應器所標示之電壓是否與供給電源相同，若與供給電源電壓不同時，則感應器需另行加裝變壓裝置否則感應器極易燒毀，連接完畢後，請再確認一次。

Warning

Please confirm WHETHER the SENSOR VOLTAGE is the same as the power supply. If different between them, need to add the TRANSFORMER, otherwise the SENSOR would be burned.

本公司另有以下各類自動門配備, 請洽本公司各經銷商
Our company has the following series of automatic door,
please contact with our distributors/representations

圓型門 Round type door

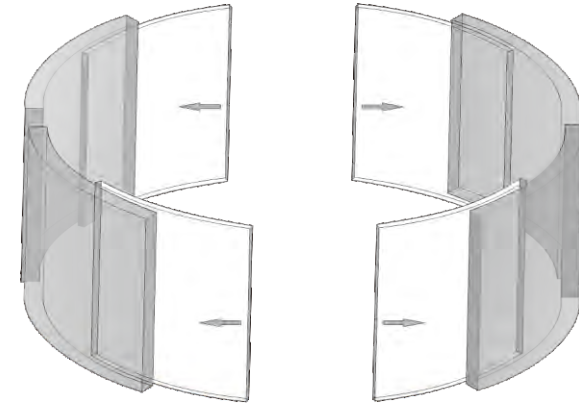

按裝方式請參考圓型門按裝說明

Installation: Please in accordance with the instruction of Round Type Door.

弧型門 Curved Type Door

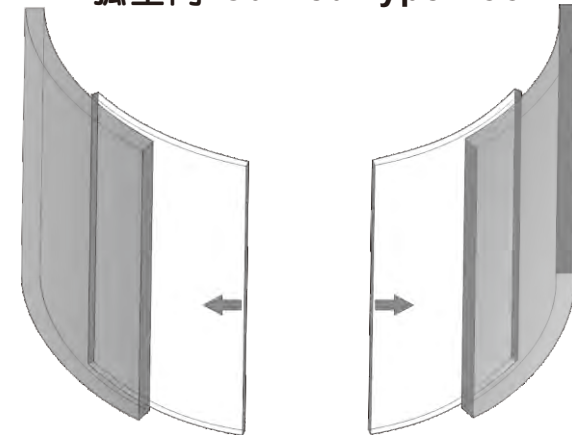

按裝方式請參考弧型門按裝說明

Installation: Please in accordance with the instruction of Curved Type Door.

四扇走雙向門

Telescopic 4-winged Sliding Doors.

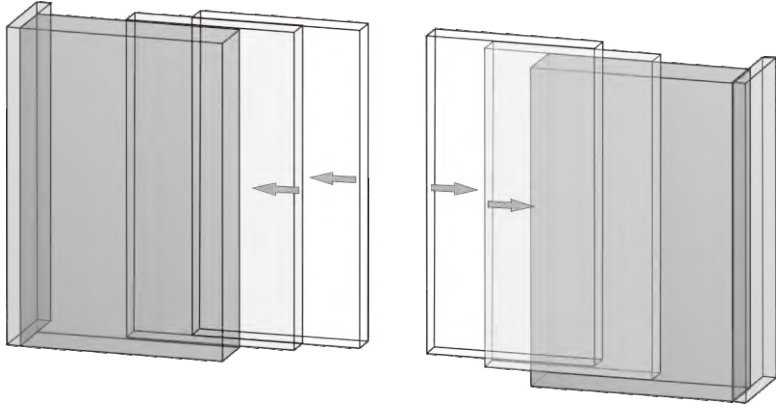

按裝方式請參考四扇走雙向門按裝說明

Installation: Please in accordance with the instruction of Telescopic 4-winged Sliding Doors.

雙扇走單向門

Telescopic 2-winged Sliding Doors.

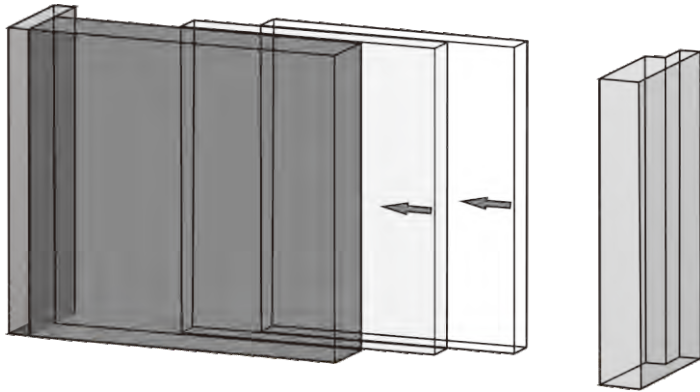

按裝方式請參考雙扇走單向門按裝說明

Installation: Please in accordance with the instruction of Telescopic 2-winged Sliding Doors.



指撥開關 I
DIP Switch I

副機關門停留角度 SLAVE postpone angle range

當主副機執行開門動作時，可設定副機停留的角度大小，以避免主副機之門扇產生碰撞問題。

When MASTER door is closing in order to avoid the SLAVE door hit it, installer can set the range to postpone the position to SLAVE.

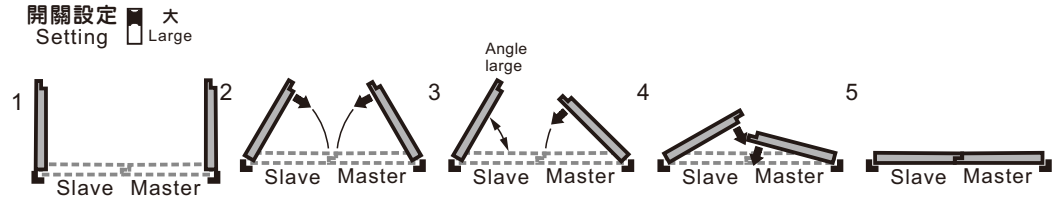
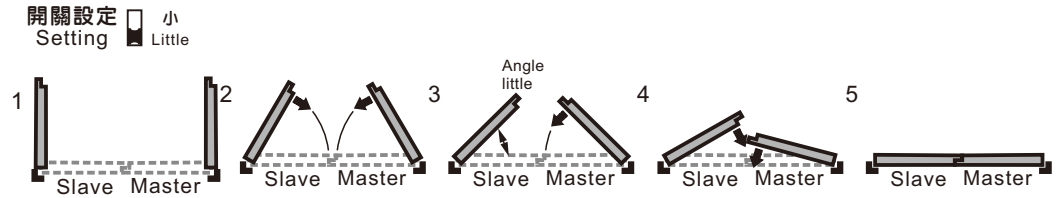

A. 雙門示意圖 Double Door

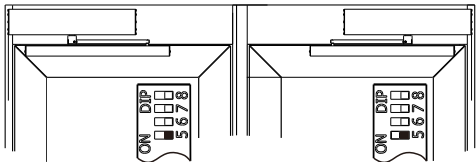

請設定二台主機指撥開關 I 第5號的狀態皆為Off。
Please set all door DIP Switch I No.5 Off.

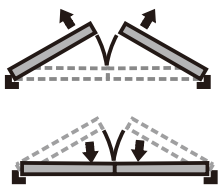

端子連接方式
Connection

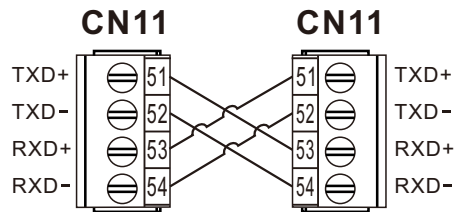

在連接端子後若黃色LED出現閃爍的狀態，表示連接成功，門扇即同步開啟與關閉。
After connecting to terminals, yellow LED flashes to indicate connecting properly. The door leaves will open and close at the same time.

B. 主從雙門示意圖 Double Door M/S

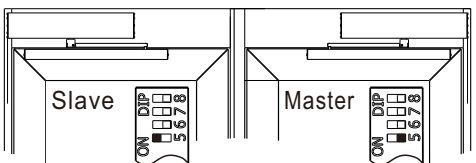

先執行關門的為主機，其指撥開關 I 的第 5 格設為 Off。後關門的為副機，其指撥開關 I 的第 5 格設為 On。
Please set the door which closes first to master and the door which closes later to slave.

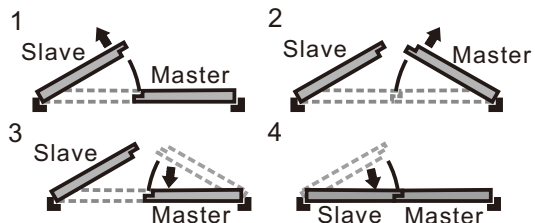

端子連接方式
Connection

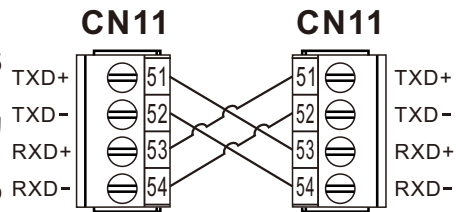

在連接端子後若黃色 LED 出現閃爍的狀態，表示連接成功。
After connecting to terminals, yellow LED flashes to indicate connecting properly.

※在送電前請檢查門片的相關位置是否正確，以免開機測試時發生錯誤。
主機與副機請同時送電，以避免開機的時間差造成開機測試錯誤。
※Before turn on the power, please inspect the relative positions of the door leaves to avoid error occurs.
Please turn on "Master" and "Slaver" at the same time to avoid the time different causes the error.

1. 產品規格 TECHNICAL SPECIFICATION..... P1
2. 門機組各部件說明 DESCRIPTION OF OPERATOR..... P2
3. 門機組尺寸圖 OPERATOR (SECTION)..... P3
4. 開門幅度設定說明 DISTANCE SETTING..... P4
5. 外推式按裝示意圖 (OUTWARD OPENING) PUSH ARM ASSEMBLY MOUNTING. P5
6. 外推式部件說明 (OUTWARD OPENING) PUSH ARM ASSEMBLY ILLUSTRATION. P6
7. 內拉式按裝示意圖 (INWARD OPENING) PULL ARM ASSEMBLY MOUNTING. P7
8. 內拉式部件說明 (INWARD OPENING) PULL ARM ASSEMBLY ILLUSTRATION..... P8
9. 各旋鈕功能說明 ADJUST BOARD INSTRUCTION..... P9
10. 動作與電鎖信號連接說明 CONNECTION -ACTIVATION AND LOCKS..... P10
11. 安全信號連接說明 CONNECTION-SAFETY..... P11
12. 雙門/主從關係
DOUBLE DOOR AND MASTER/SLAVE FUNCTION..... P12
13. 電器連接 CONNECTION..... P13

型號 MODEL	SW-5E	
種類 TYPE	外推式 (Outward)	內拉式 (Inward)
門扇重量/寬度 DOOR WEIGHT & WIDTH	<p>最大值: ● Max.</p> <p>最小值: ● Min.</p>	
馬達 MOTOR	DC24V 150W 直流無刷馬達 DC24V 150W BRUSHLESS DC MOTOR	
控制器 CONTROL	微電腦化處理機控制器 USER-FRIENDLY MICRO-CONTROLLER	
消耗電量 POWER CONSUMPTION	150W	
電源電壓 VOTAGE	AC100V~240V	
環境溫度 ENVIRONMENTAL TEMPERATURE	-20°C ~ +50°C	
噪音量 VOLUME	最大 55 分貝 55 decibel(max.)	
開啟速度 SPEED of OPENING 90 DEGREE	最大值: 3 秒 ~ 15 秒 / 90° 3~15 sec. (Max)	
開啟時間 STARTING TIME	可調 0 秒至 20 秒 0~20 sec. (Regulable)	
傳動要件 TRANSMISSION IMPORTANT CONDITION	外推式連桿組 Outward Arm assembly	內拉式滑動槽 Inward Arm assembly
開門幅度 OPENING DOOR RANGE	自行設定/ 90° (出廠值) 120°Max./90 (default)	
PFC 功率因素 POWER EFFICIENCY	0.95(AC100V全載時) 0.95 (In full load)	
手推開啟力量 TRACTION FORCE	3 kg	

ENTRY SENSOR ACTIVATION

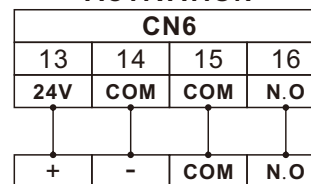

HR50

EXIT SENSOR ACTIVATION

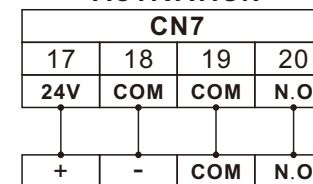

HR50

PREMIER SWING ONDOOR SAFETY (NOT MONITORED)

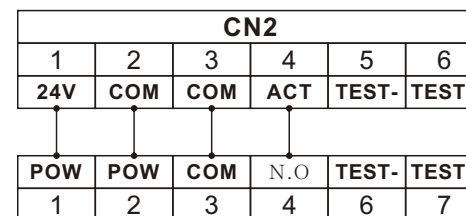

HOTRON SSS-5

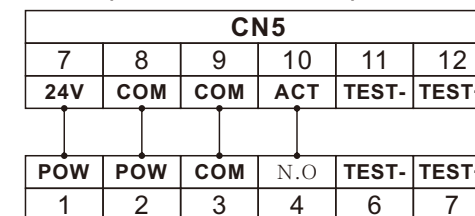

HOTRON SSS-5

OPEN FACE SAFETY (TOPSCAN)

CONTROLLER PANEL
DIP Switch II No.1 → "ON"
SSS-5
DIP Switch No.1 → "A"

CLOSE FACE SAFETY (TOPSCAN)

CONTROLLER PANEL
DIP Switch II No.4 → "ON"
SSS-5
DIP Switch No.1 → "A"
No.3 → "N.C"

PREMIER SWING ONDOOR SAFETY (MONITORED)

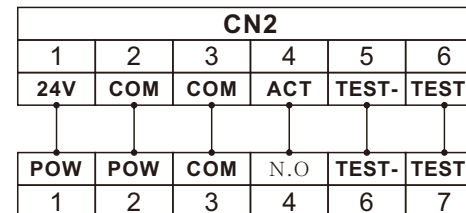

HOTRON SSS-5

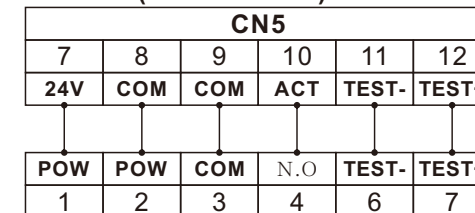

HOTRON SSS-5

OPEN FACE SAFETY (TOPSCAN)

CONTROLLER PANEL
DIP Switch II No.1 → "ON"
No.2 → "ON"
SSS-5
DIP Switch No.1 → "A"

CLOSE FACE SAFETY (TOPSCAN)

CONTROLLER PANEL
DIP Switch II No.4 → "ON"
No.5 → "ON"
SSS-5
DIP Switch No.1 → "A"

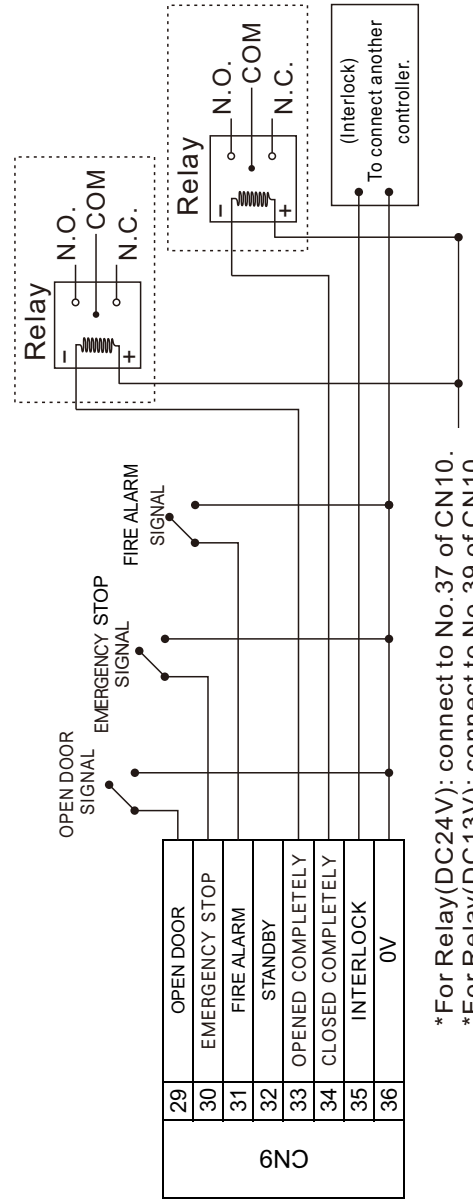

* For Relay(DC24V): connect to No.37 of CN10.
 * For Relay(DC13V): connect to No.39 of CN10.

Warning

- *Relay it should be with built in diode.
- *Relay Suggested model: OMRON MY2N-D2-J (It's arranged by customers)

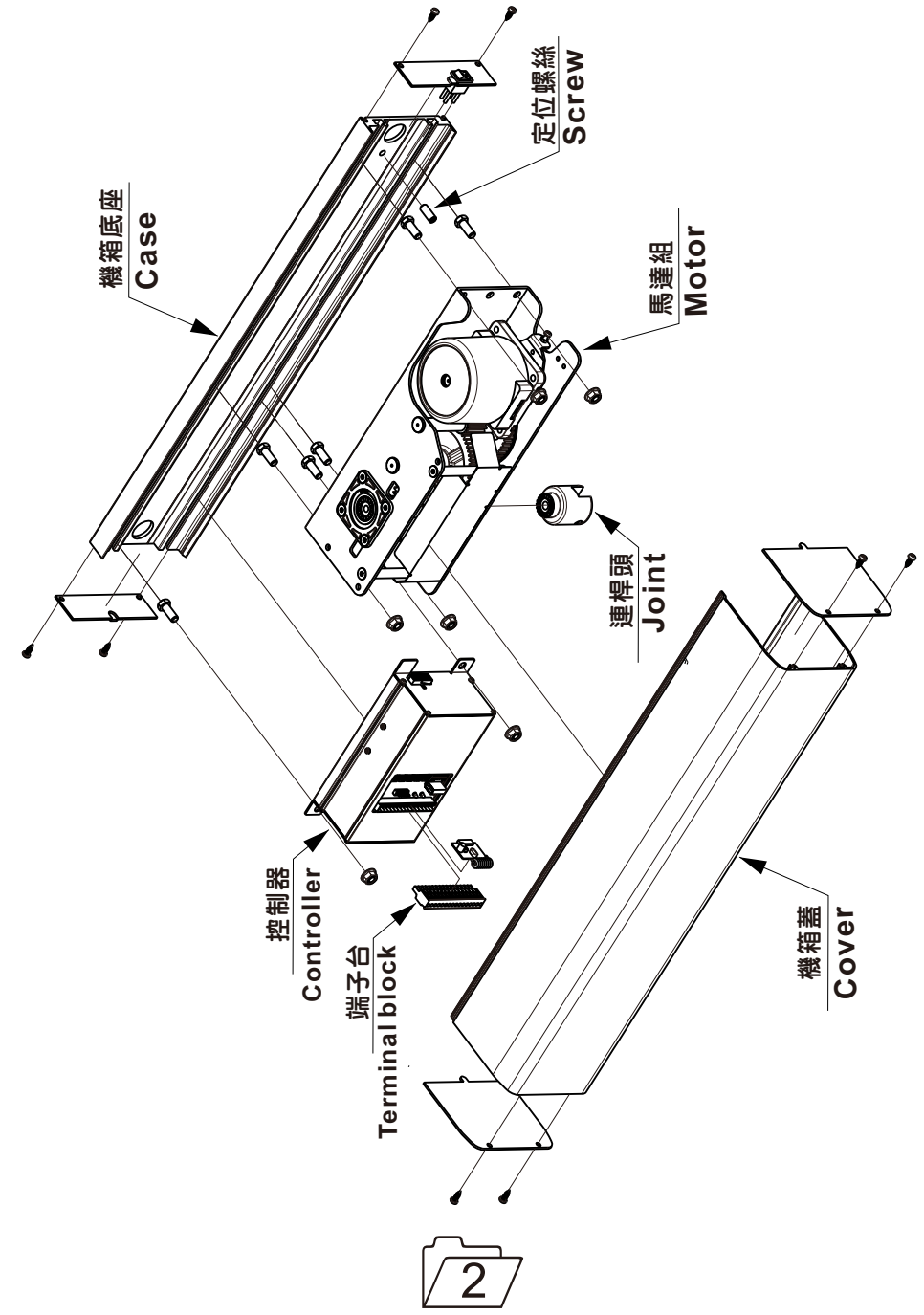
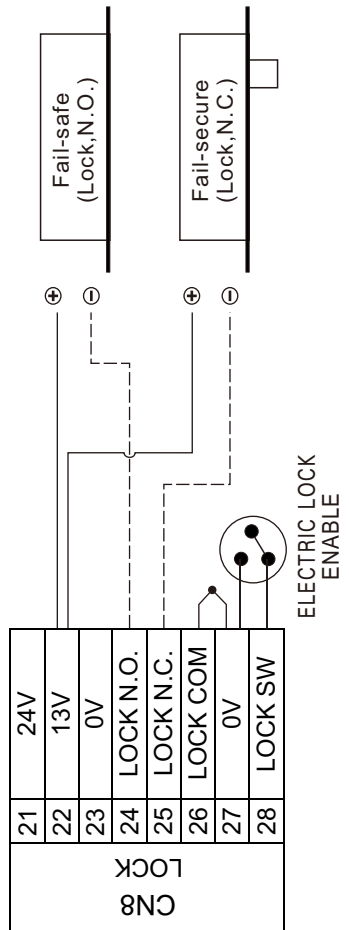

正視圖

Front View

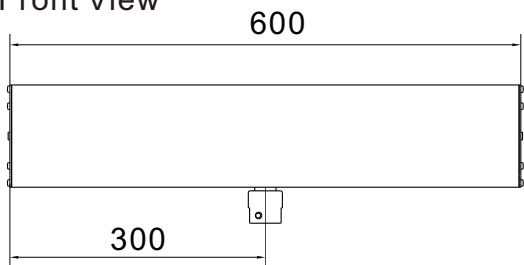

側視圖
Side View

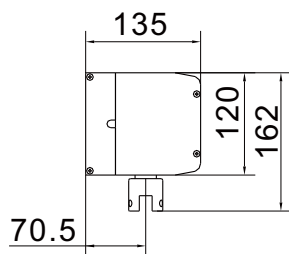

底座尺寸圖

Base Size

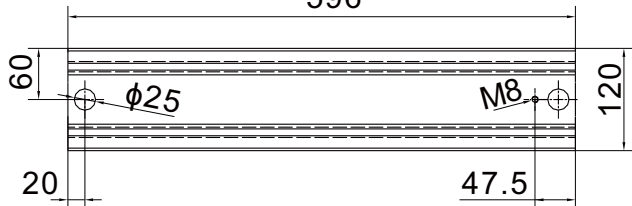

每組門機皆可搭配內拉或外推式配件

Every set of operator can use the Inward / Outward Arm assembly.

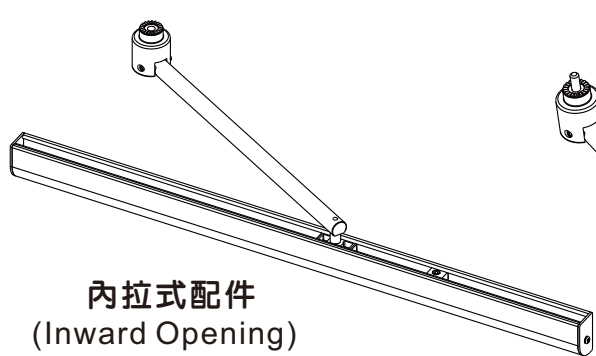

內拉式配件
(Inward Opening)
Pull Arm assembly

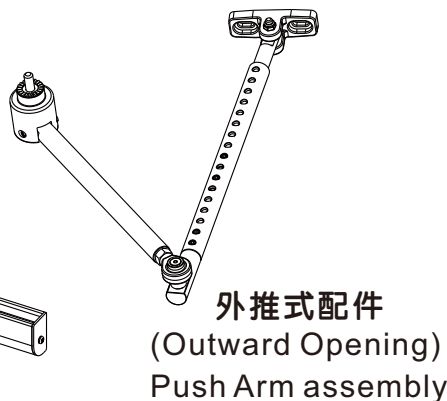

外推式配件
(Outward Opening)
Push Arm assembly



指撥開關 II
DIP Switch II

- 1 門後開關
 N.O N.C
- 2 門後開關自我測試
 No Yes
- 3 門後開關動作模式
 停止 慢速
- 4 安全光線
 N.O N.C
- 5 安全光線自我測試
 No Yes
- 6 門外感應器
 N.O N.C
- 7 門內感應器
 N.O N.C
- 8 緊急停止
 N.O N.C

PS:指撥開關有切換時
要重新啟動電源

- 1 Open Face Safety
 N.O N.C
- 2 Open Face Safety Test
 No Yes
- 3 Open Face Safety Type
 Stop Slowly
- 4 Closing Face Safety
 N.O N.C
- 5 Closing Face Safety Test
 No Yes
- 6 Entry Sensor
 N.O N.C
- 7 Exit Sensor
 N.O N.C
- 8 Emergency stop
 N.O N.C



指撥開關 III
DIP Switch III

- 1 無管制開門
 N.O N.C
- 2 火災警報
 N.O N.C
- 3 火災動作
 開門 關門
- 4 ~ 8 保留

- 1 Open
 N.O N.C
- 2 Fire Alarm
 N.O N.C
- 3 Fire Alarm Type
 Open Close
- 4 ~ 8 Standby



指撥開關 I
DIP Switch I

- 1 左/右開設定**
 右開 左開
- 2 煞車開關設定**
 有煞車 無煞車
- 3 副機關門停留角度**
 小 大
 *設定說明請參考第16頁
- 4 定向開關設定**
 OFF ON
 OFF: 正常模式
 ON: 系統模式為按一下開門，再按一下關門。
- 5 主/副機模式設定**
 主機 副機
- 6 電鎖模式設定**
 一般電鎖 斜舌式
- 7 門後長度失效偵測設定**
 手動 自動
 Ps手動是由K8旋鈕設定
 自動是開機時自動偵測設定
- 8 反向開關設定**
 關閉 開啟
 OFF(正常模式): 停電再復電後，門扇先執行開門動作。
 ON(適合保全系統): 停電再復電後，門扇先執行關門動作。

PS:指撥開關有切換時
要重新啟動電源

- 1 L/R Switch**
 Right Left
- 2 Brake power switch**
 OFF ON
- 3 SLAVE postpone angle range**
 Little Large
 *Please ref. to P16
- 4 Directional function**
 OFF ON
 OFF: Normal mode.
 ON: Push once, open the door.
 Push again, close the door.
- 5 MASTER/SLAVE setting**
 Master Slave
- 6 Electric lock type setting**
 Normal Latch Bolt
- 7 "Non-detect angle" for safety sensor Setting.**
 Manual Learn
 "Manual setting" has to adjust by "K8" knob.
- 8 Reverse Switch:**
 in order to control opening and closing
 OFF ON
 OFF: Normal mode, after power resumes, the Door-Leaf opens the door first.
 ON: suitable for Security System, after power resumes the Door-Leaf closes the door first.

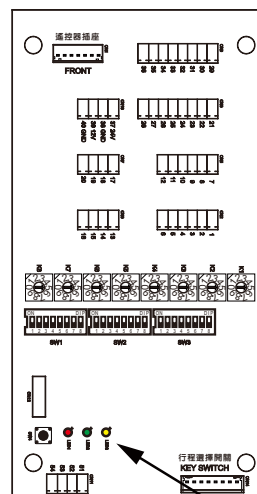
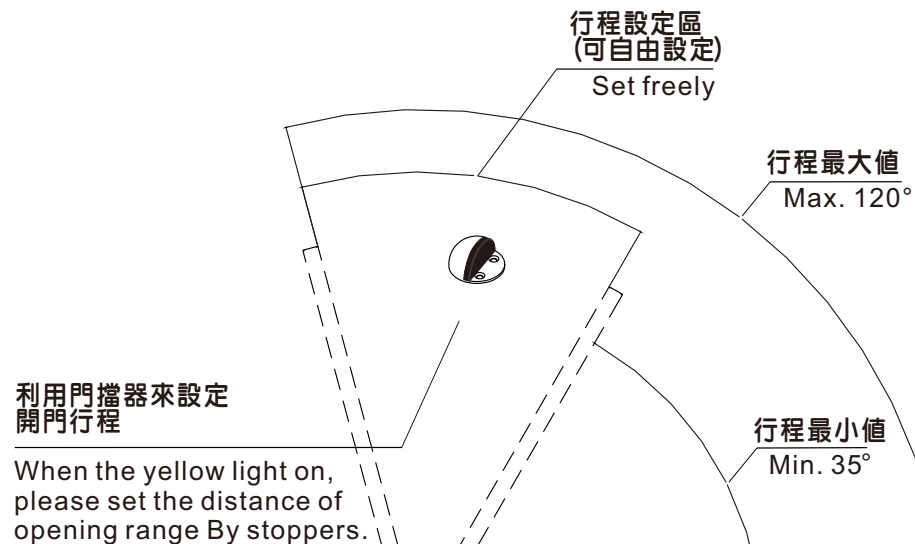

黃 LED 開機測試

Yellow LED Opening Testing

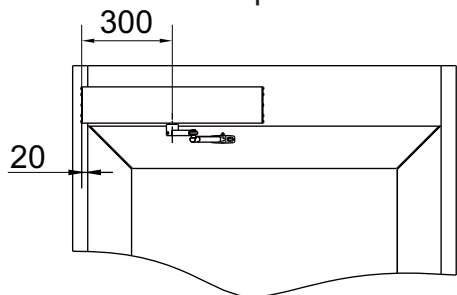
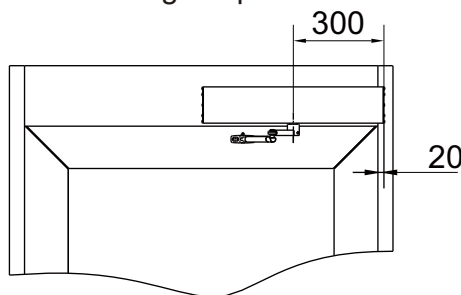
外推式 (左側)
Left Open外推式 (右側)
Right Open

外推式推桿按裝尺寸圖

The position of mounting

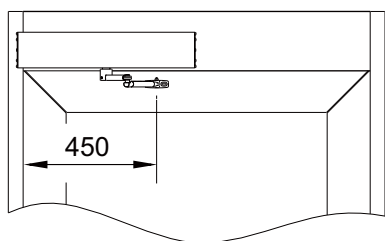

外推式門機按裝尺寸圖

Mounting (Side View)

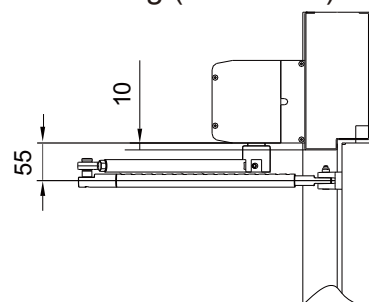
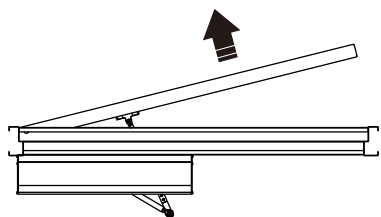
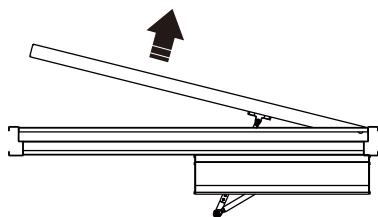
外推式開門方向 (左側開門)
Mounting
(eg. for left Open, Top View)外推式開門方向 (右側開門)
Mounting
(eg. for Right Open, Top View)**K1 開門速度調節旋鈕 The opening speed of the door**

可調整門扇開啟時行進速度，數字越大，速度越快。初始調整時，請將數字由小而大，逐次調整。

Adjust the OPEN SPEED. Higher number, faster speed.

CAUTION: please adjust the number one by one from low to high.

**K2 關門速度調節旋鈕 The closing speed of the door**

可調整門扇關閉時行進速度，數字越大，速度越快。初始調整時，請將數字由小而大，逐次調整。

Adjust the CLOSED SPEED. Higher number, faster speed.

CAUTION: please adjust the number one by one from low to high.

**K3 開門慢速速度調節旋鈕**

可調整門扇開啟時慢速速度，數字越大，力量愈大。初始調整時，請將數字由大而小，逐次調整。

**K4 關門慢速速度調節旋鈕**

可調整門扇關閉時慢速速度，數字越大，力量愈大。初始調整時，請將數字由大而小，逐次調整。

**K5 開門時間調節旋鈕 Opening hold time**

調整門扇開放時間，數字越大，門扇停留時間越長，在最小(0)秒和最大(120)秒之間調整。

Adjust the HOLD OPEN TIME. Higher number, the hold time is longer.

NUMBER	0	1	2	3	4	5	6	7	8	9
SECOND	0	1	2	3	4	5	6	10	15	20

**K6 碰撞偵測靈敏度調節旋鈕 Sensitivity of Collision Detection**

可調整偵測門扇在運行中遇到阻礙時的反應靈敏度，數字越小靈敏度愈高。初始調整時，請將數字由小而大，逐次調整。

Adjust the sensitivity of reaction to obstacle during door is working, less number, higher sensitivity.

CAUTION: please adjust the number one by one from low to high.

**K7 煞車力調節旋鈕 Brake Power**

調整門扇的煞車力量，數字愈大煞車力愈強。

Adjust Door-Leaf BRAKE POWER. Higher number, more Brake power

**K8 門後防撞失效距離旋鈕**

數字	0	1	2	3	4	5	6	7	8	9
角度	Desable	4/90°	8/90°	12/90°	16/90°	20/90°	24/90°	28/90°	32/90°	36/90°

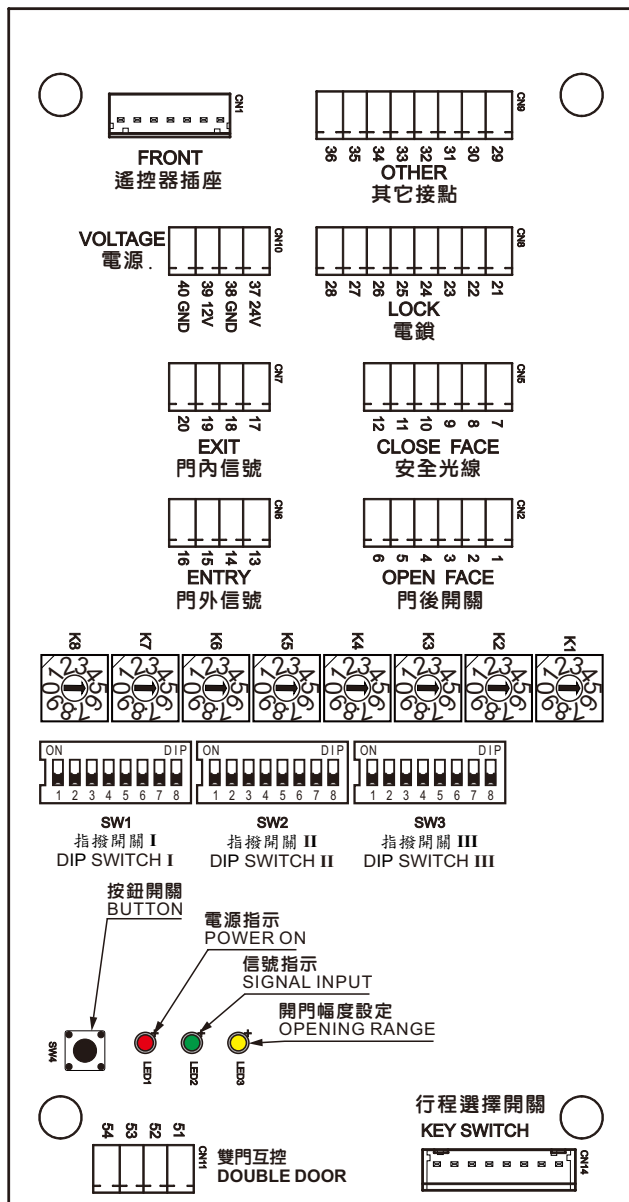

黃色 LED : 設定開門幅度 (燈亮表示設定行程中)

Yellow LED : Setting door opening range. (When light on you can set the door range.)

綠色 LED : 燈亮表示信號已輸入
Green LED : Signal input.

紅色 LED : 電源指示燈 (燈亮表示電源已接通)

外推式按裝示意圖
Operator

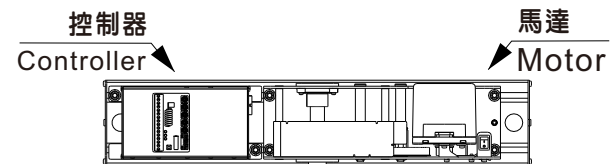

註：無論是外推式和內拉式，左側門或右側門馬達永遠是按裝在右側。
Motor has to be mounted the right side of the controller, no matter it's Outward/Inward/Left Open/Right Open.

外推式連桿示意圖
Inward Opening
Push Arm assembly

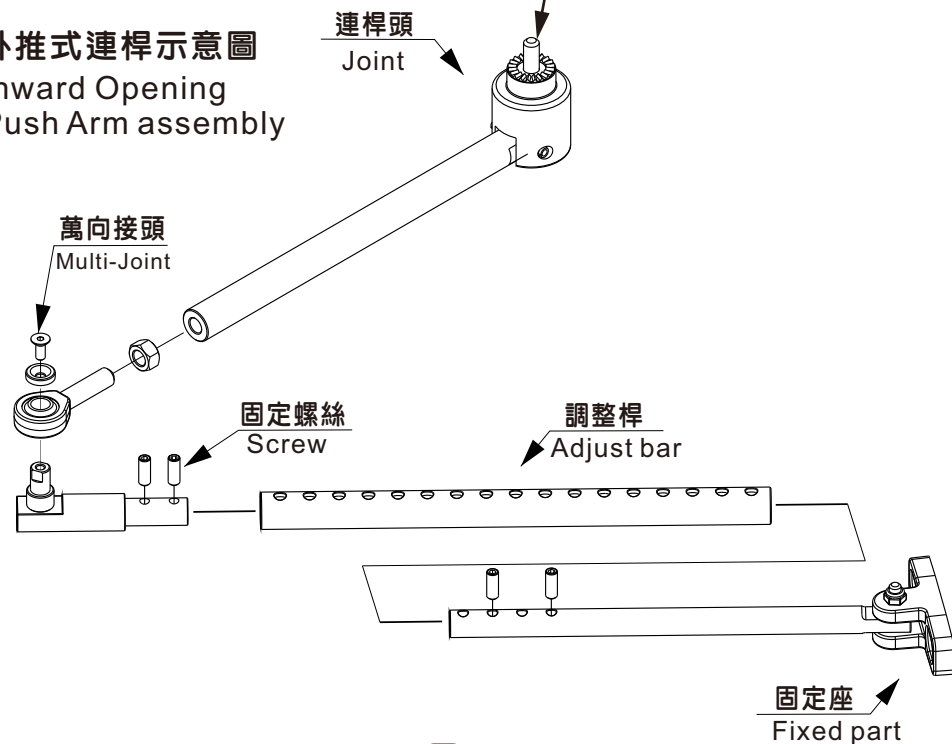

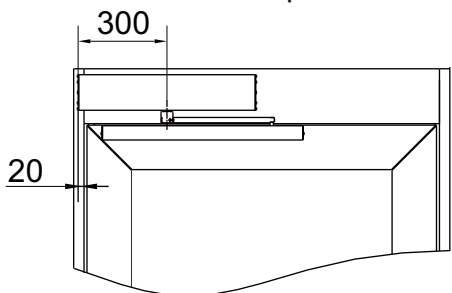
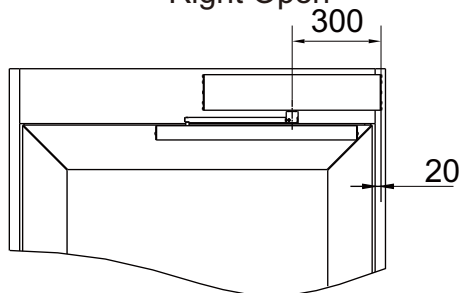
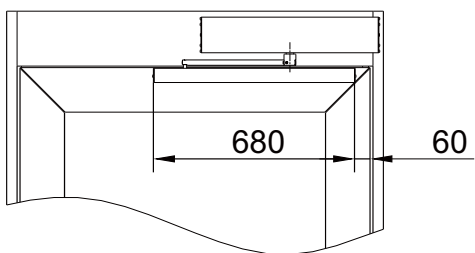
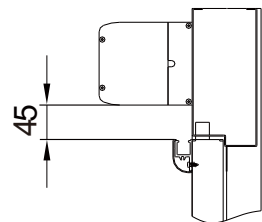
內拉式 (左側)
 Left Open

內拉式 (右側)
 Right Open

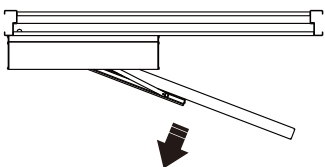
內拉式滑動槽按裝尺寸圖
 The position of mounting

內拉式門機按裝尺寸圖
 Mounting (Side View)

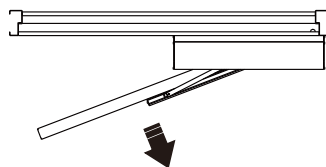
內拉式左側開門方向
 Mounting

(eg. for Left Open, Top View)

內拉式右側開門方向
 Mounting

(eg. for Right Open, Top View)

內拉式按裝示意圖

Operator

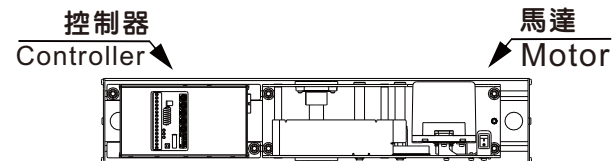
連桿頭

Joint



註：無論是外推式和內拉式，左側門或右側門馬達永遠是按裝在右側。
 Note: Motor has to be mounted the right side of the controller, no matter it's Outward / Inward / Left Open / Right Open.

內拉式滑槽示意圖

Inward Opening Pull Arm assembly

